

## PRO 700: BASE UNITS TO SUPPORT BRIDGE UNITS

### 4 base units with multiples function options:

- GN tray slides with hygienic covered edge base shelf
- Drawers GN1/6
- Electric hot cupboard
- Open base
- Cupboard with doors

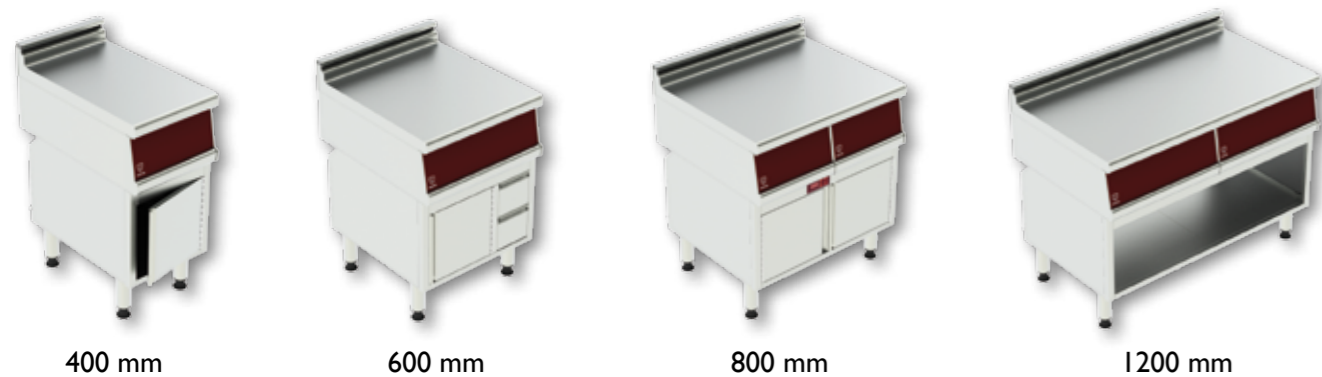

## PRO 700: OPTIONS AND PERSONNALISATION

- Bright polish rail with PVC end caps
- Removable plating shelves
- Chefs sink
- One piece top to special order
- Castors
- G/N drawers
- Mixer tap
- Removable plinth panels

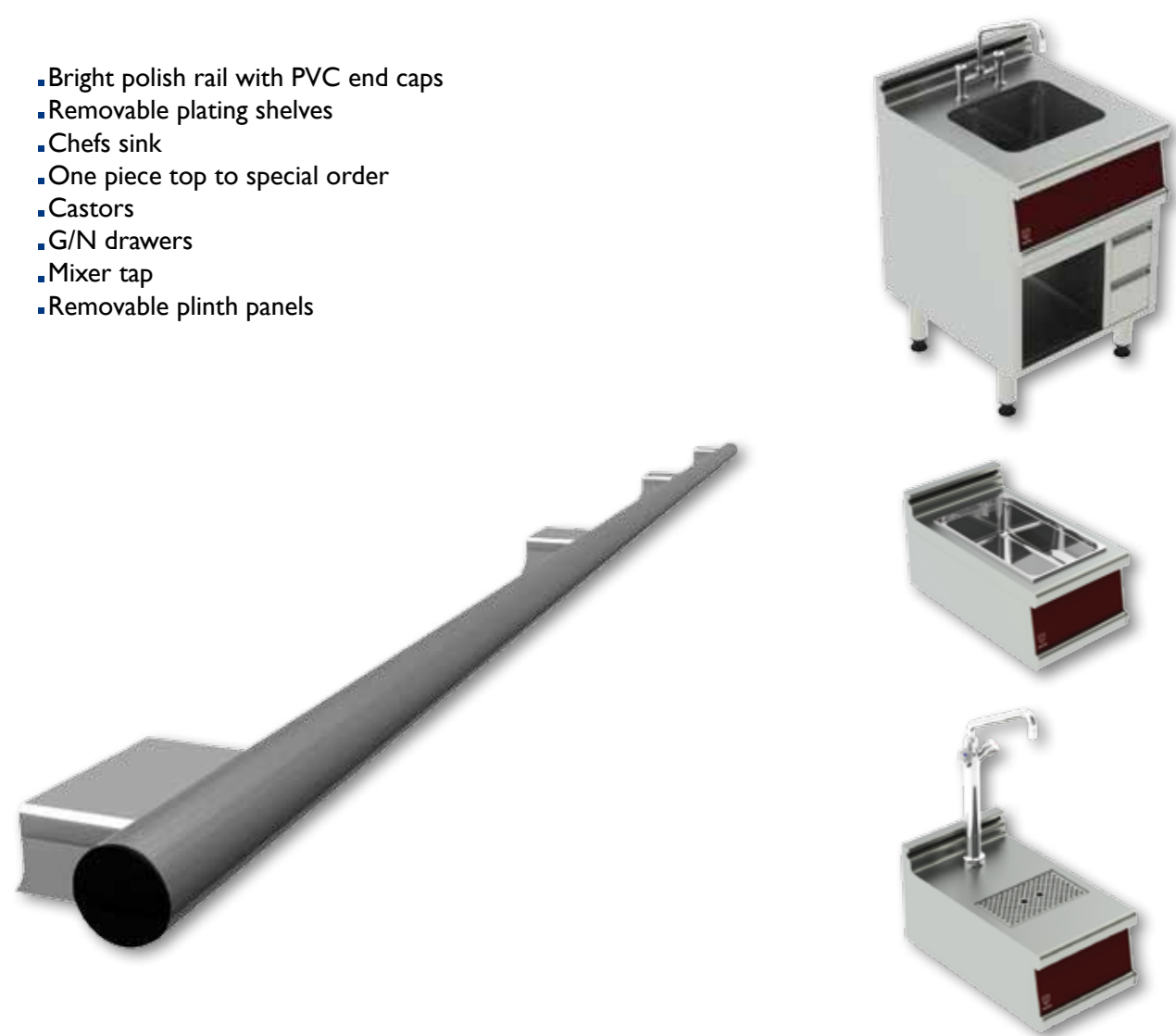

### Heavy duty construction

- Stainless steel construction throughout
- 2mm.thick work tops
- Stainless steel legs – 180/210mm. H
- Enamelled control panels and indicator markings



### Hygiene

- Precision butt joint assembly
- Covered rear upstand incorporation flues
- Enamelled trays and drawers under open burners
- Nickel coated steel pan supports
- Vertical stainless steel cover between modules
- No visible screws



### Performance

- 6.5kw open burners with integrated pilots
- Flush solid tops with refractory plates under
- GN2/1 gas or electric ovens
- Multitube enamelled burners for even temperature on ovens, griddles and planchas.



### Personnalisation

- One piece work tops to special order
- Stainless steel plinth panels
- Enamelled panels – choice of colour available
- Central island, wall and cantilever cooking suite configurations
- Compatible with under counter refrigeration



1170, rue Principale BP 3, 38850 Charavines France - Tél : 33 (0) 476 066 422 - Fax : 33 (0) 476 557 875  
www.charvet.fr - info @charvet.fr

AUTHENTIC KITCHEN EQUIPMENT



## PRO 700 SERIES



## The compact range from Charvet



- A complete range for smaller kitchens
- Compact
- High performance
- Heavy Duty



Non contractual document : Charvet keeps the right to modify the technical characteristics without any advise. Design : Wainhee 06.28.34.79.53 - March 2013.

PRO 700 SERIES



**PRO 700: GAS AND ELECTRIC OVEN RANGES**

**FULL MODULES - 800 W. - 700 D. - 900 mm H.**



- Gas and electric GN2/I static ovens
- Fan assisted GN1/I electric ovens (available 2014)

**PRO 700: BRIDGE UNITS 600 mm W**

**600 mm. GAS – ELECTRIC AND NEUTRAL UNITS  
600 W. - 700 D. - 280 mm. H.**



- Large gas solid top (8 kW)
- Gas chrome plancha (7 kW) & electric (5.5 kW) – 400 x 500 mm
- Gas steel plancha (7 kW) & Elec (5.5 kW) 400 x 450 mm
- 4 electric boiling plates 220 x 220 mm (10.4 kW)

**PRO 700: BRIDGE UNITS 400 mm W**

**400 GAS MODULES - 400 W. - 700 D. - 280mm. H.**

- 2 open burners under nickel coated steel pan support – 330 x 520 mm (6.5 kW each)
- Solid tops – 330 x 520 mm (5 kW each)
- Ribbed/smooth cast griddles – 350 mm x 495 mm (7 kW)
- Chrome ribbed/smooth griddles – 365 x 500 mm (7 kW each)
- Chargrill (8 kW)



**PRO 700: BRIDGE UNITS – 800 mm W. (280mm H.)**

**800 mm GAS – ELECTRIC AND NEUTRAL UNITS – 800 W. - 700 D. - 280 H.**

- 4 open burners under nickel coated steel pan support – 330 x 520 mm (6.5 kW each)
- 2 solid tops – 330 x 520 mm (5 kW each)
- 1 solid top + 2 open burners (6.5 kW each)
- 2 open burners + 1 solid top
- 2 ribbed / smooth cast griddles – 350 x 495 mm (7 kW each)



- 4 electric plates – 220 x 220 mm (2.6 kW each)
- 4 radiant hobs under vitroceramic cooking surface (2.1 kW each)
- 2 ribbed/smooth cast griddles – 350 mm x 495 mm (3.3 kW)
- 2 chrome ribbed/smooth griddles – 365 x 500 mm (3.3 kW each)
- Bain-marie GN2/I (3 kW)
- Pasta cooker (4 kw) with 4 square baskets GN1/6
- 2 x 8L fryers (7.5 kW each) - **bridge unit or technical cupboard**
- 2 x 14L fryers (12 kW each) - **on technical cupboard only**

**PRO 700: CONFIGURATIONS**



Wall Suite with bridge units to allow roll under refrigeration.



Central island cooking suite of bridge units on base supports and freestanding units.



Central island of bridge units suspended on central services wall.

**400 ELECTRIC MODULES - 400 W. - 700 D. - 280mm. H.**

- 2 electric plates – 220 x 220 mm (2.6 kW each)
- 2 radiant hobs under vitroceramic cooking surface (2.1 kW each)
- Ribbed/smooth cast griddles – 350 mm x 495 mm (3.3 kW)
- Chrome ribbed/smooth griddles – 365 x 500 mm (3.3 kW each)
- 2 x 7L fryers (8 kW each) – **on technical cupboard**
- 14 L fryers (12 kW each) – **on technical cupboard**
- 8 L fryers (7.5 kW each) – **bridge unit or technical cupboard**
- Bain-marie GN2/I (3 kW)
- Gas and electric GN2/I static ovens
- Fan assisted GN1/I electric ovens (available 2014)
- Induction 2 x 3.5 kW diam 220 mm

